



LA 180L

en Operating instructions

A



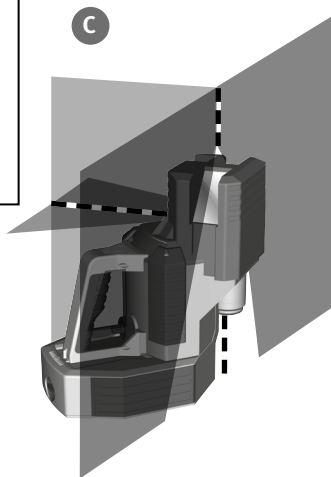
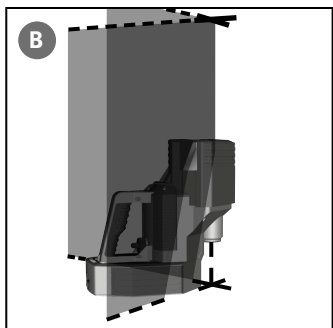
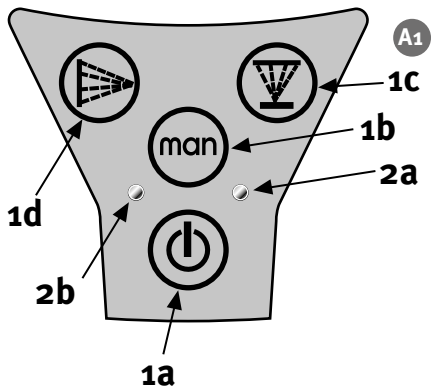

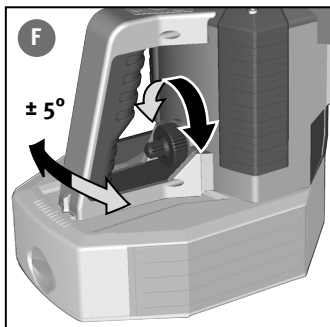
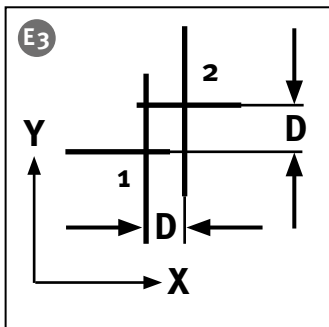
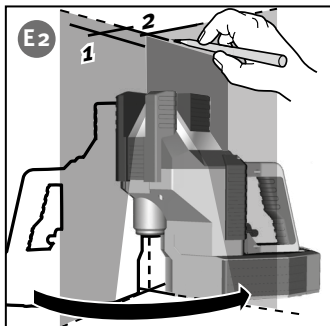
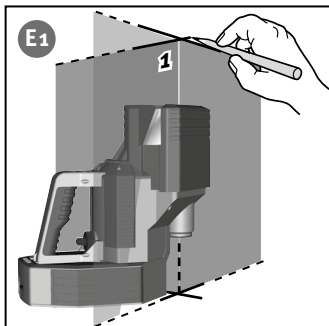
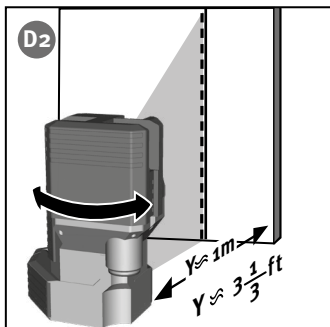
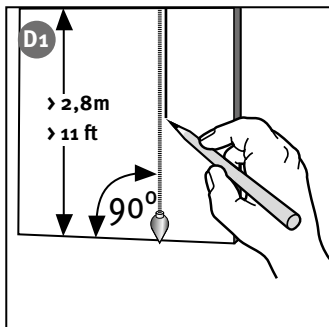

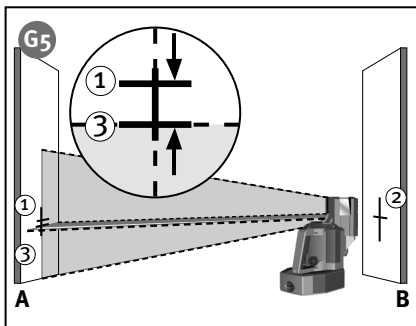
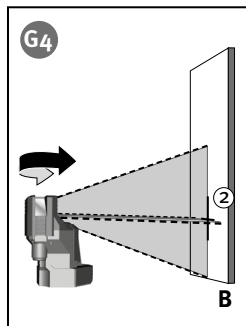
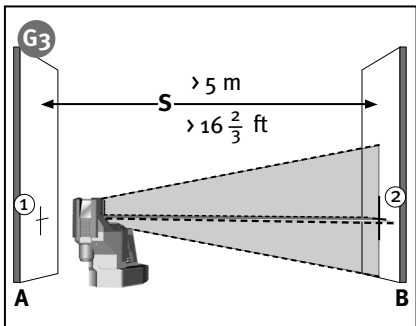
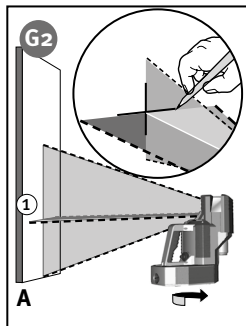
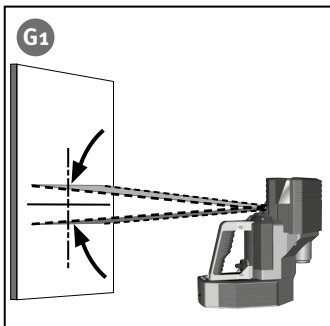
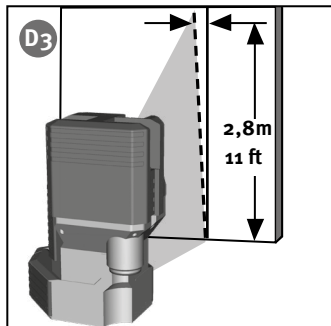

Operating instructions

The STABILA LA 180L instruments are easy-to-use multi-line lasers.

They are self-levelling within the range of $\pm 5^\circ$ and enable the user to level quickly and precisely. The vertically and horizontally projected laser lines provide exact alignment / working. The LA 180L has a motorised fine adjustment facility for 90° angle positioning. The pulsed laser lines allow the instrument to operate over long distances using a special line receiver (-> see Operating Manual, Line Receiver)

We have endeavoured to explain the unit's handling and functioning in as clear and comprehensible manner as possible. If you have any technical questions, you can contact us at any time. Telephone number:

+49 / 63 46 / 3 09 - 0

1.800.869.7460 U.S. and Canada

Main components

A1

(1) Selector switch:



(1a) On/off button



(1b) Button: automatic levelling on / off - manual mode



(1c) Button : horizontal line on/off



(1d) Button : vertical lines on/off

(2) LEDs for displaying:

(2a) LED green : Operating mode ON or READY / OK

(2b) LED red : battery voltage and overheat

A

(3a) Exit aperture for the horizontal and vertical laser lines

(3b) Exit aperture for vertical beam

(4) Battery compartment

(5) Upper part

(6) Adjusting screw: precision adjustment to alignment of vertical laser lines

(7) Shock protection

(8) 5/8" threaded connector for tripod

(9) REC 410 Line RF receiver

Recycling programme for our EU customers:

In accordance with the WEEE regulations, STABILA provides a disposal programme for electronic products at the end of their service life.

For more details, please contact: +49 / 6346 / 309 - 0



NB:

In Class 2 laser equipment, your eyes are normally protected from accidental, short-term exposure to the laser beam by the lid-closing reflex and/or the reflex reaction to turn one's head. If a laser beam should encounter your eye, you should consciously close your eyes and immediately move your head out of the beam. Do not look directly into the direct or reflected beam. The laser goggles enclosed with these units are not safety goggles. They are designed to make the laser beam easier to see. The use of operating and adjustment equipment other than that indicated here or the use of other procedures can lead to dangerous exposure to radiation. Alterations (manipulation) to the laser instrument by the customer is not permitted. These Operating Instructions must be retained and passed to the next user of the laser instrument.

Do not direct the laser beam at people.

Do not let the unit fall into children's hands !

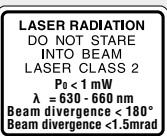

CAUTION



Main applications:

Operating modes

The LA 180L can be used in 2 operating modes:

1. as a self-levelling line laser
 - for horizontal levelling
 - for vertical alignments
 - for plumb-lining
 - for constructing 90° angles
2. as a laser instrument for marking applications without the levelling function.

Operating mode with self-levelling

Commissioning

The instrument is turned on with the on/off switch (1a). Vertical laser lines and a plumb point appear after switching on. However, if only the horizontal line was on just prior to the last time the instrument was switched off, the horizontal laser line will appear when the instrument is turned on.

The laser is automatically aligning itself all the while the laser lines are flashing (< 15 seconds). Flashing frequency: slowly



(1a)

Setting the type of line:



(1c)

Button (1c): switches the horizontal laser line on/off. The horizontal laser line can only be switched off if at least one vertical laser line is switched on. The horizontal laser line can be used, for example, for levelling over long distances or for the horizontal alignment of building components and members.

C



(1d)

Button (1d): different vertical laser lines can be switched on / off in succession. The plumb-line point is also switched on / off at the same time. All the vertical laser lines can only be switched off if the horizontal laser line is switched on. If button 1d is pressed again, the vertical laser lines are switched on again in their last configuration. Single vertical laser lines can be used, for example, for marking out vertical planes or aligning vertical building components or members.

If the inclination is too great the laser and the LED display flash (green)!

laser beam **flashing**-> The unit is inclined too much
+ is outside the self-levelling range
+ the laser cannot level itself automatically

Plumb-lining:

B

As described in "Setting the Type of Line", at least 2 vertical lines at an angle of 90° to each other are switched on. These two lines intersect above the plumb point below so that the plumb points can be transferred from the floor to the ceiling.

Constructing 90° angles:

As described in "Setting the Type of Line", at least 2 vertical lines at an angle of 90° to each other are switched on.. This 90° angle can, for instance, be used to check 90° angles or align items at a right angle to each other.

The fine adjustment facility described below makes this work significantly easier.

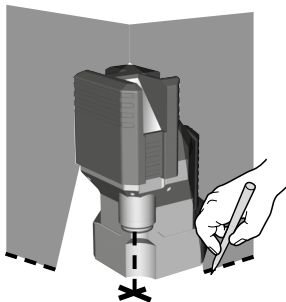
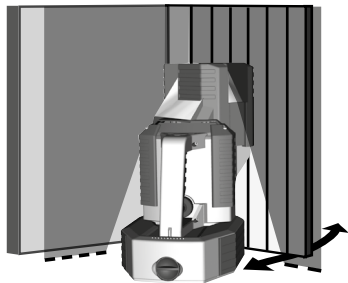

Fine adjustment

Using the adjusting screw, the upper part can be rotated through $\pm 5^\circ$ around its vertical axis, enabling a vertical laser line to be aligned precisely with a reference line. With the LA-180L, the fine adjustment procedure can also be undertaken using the receiver.

F

Operating mode without levelling function.

Button (1b): the levelling function is switched off.

In this mode the laser lines flashes. Flashing frequency: rapid

Checking the calibration

The LA180L multi-line laser was designed for use on construction sites and was perfectly adjusted when it left our factory. As with any precision instrument, however, its calibration must be regularly checked. The unit should be checked before starting any new tasks, particularly when the unit has been exposed to strong vibrations. After an impact, the unit should be checked throughout its whole self-levelling range.

Vertical check

1. Vertical accuracy check

You must create a reference to perform this test. Fasten a plumbline near to the wall. The laser unit should now be set up in front of this reference mark (distance Y) and the vertical laser line compared with it.

The discrepancy between the centre of the laser line of the multi-line laser and the reference mark should be no greater than 1 mm / $3/64''$ from the reference mark over a length of 2.8 m / 11 ft. This vertical check should be undertaken separately for all vertical laser lines.

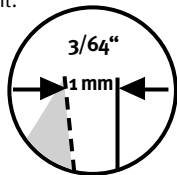

D1

D2

D3

2. Checking plumb-lining

1. Set up the instrument
2. Switch on the instrument - button (1a)
3. Switch on the vertical laser lines - button (1d)
4. Place the laser so that its down beam is aligned over a reference mark on the floor.
5. Mark the position of the laser cross on the ceiling.
6. Rotate the laser through 180° and realign the laser beam on the reference mark on the floor.
7. Mark the position of the laser cross on the ceiling.
8. Measure the differences in the x and y directions between the two marks on the ceiling. The difference is twice the actual error. In each case the difference may not be greater than 4 mm in 6 m / $5/64''$ in 10 ft.

E1

E2

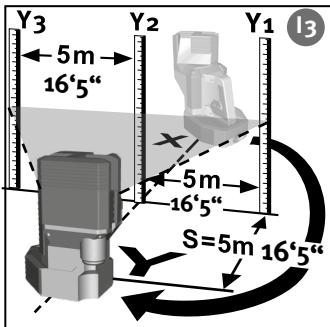
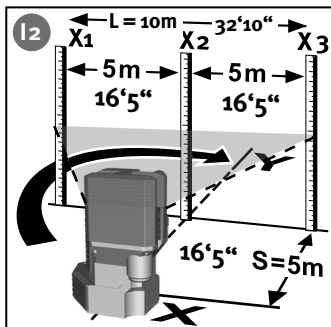
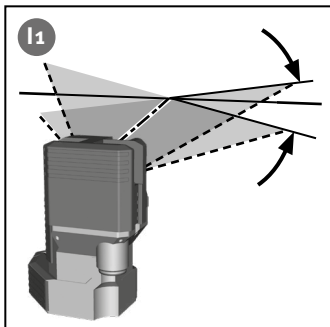
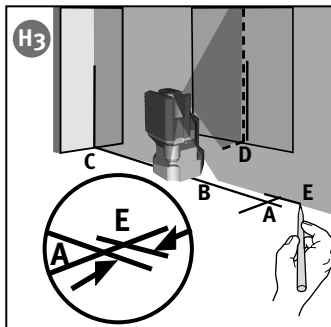
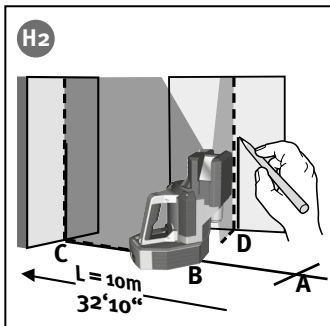
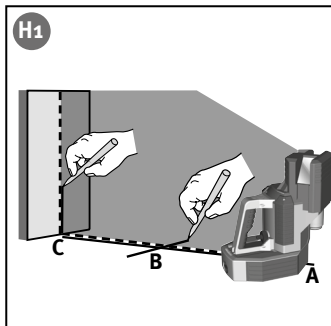

3. Checking the angular accuracy of the vertical lines:

checking the 90° angle of the vertical lines.

Checking 90° angle I

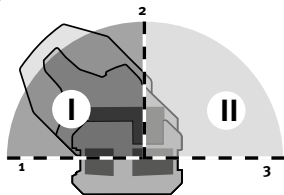

1. Choose a room which is at least 10 m (32'10") long.
At one end mark point „A“ on the floor. H1
2. Align the laser with its plumb-line beam directly over point „A“.
Ensure that laser line 1 can be seen at the opposite end of the room.
3. At about the middle of the room mark point „B“ on the floor.
4. Mark point „C“ on the opposite wall or on the floor.
5. Move the LA-90L (LA-180L) to point B and realign laser line 1 on point „C“.
6. Mark position „D“ of the right-angle laser line 2 on the floor. H2

Note:

In order to guarantee accuracy, the distance of „A“ to „B“, „B“ to „C“ and „B“ to „D“ should be equal.

7. Rotate the LA-90L (LA-180L) through 90° so that laser line 1 is aligned with point „D“.
8. Mark position „E“ of the right-angle laser line 2 as close as possible to point „A“ on the floor.
9. Measure the distance between points „A“ and „E“.

Length of the room or distance between points „A“ and „C“.	Each of the 90° angles are accurately calibrated if the distance between points „A“ and „E“ is as follows:
10 m	≤ 2,0 mm
20 m	≤ 4,0 mm
32'10"	≤ 5/64"
65'8"	≤ 5/32"

90° angle II is checked using the same method but using only laser lines 2 and 3. H3

Horizontal checking

G1 1. Horizontal checking - Line level

G2 Two parallel wall surfaces at least 5m / 16'5" apart are required for the horizontal check.

1. Place the LA180L on a smooth surface or on a tripod as close as possible to wall A and with the front side pointing towards the wall
- (1a) 2. Switch the unit on - button (1a)
- (1c) 3. Switch on the horizontal laser line - button (1c)
- (1c) 4. Switch on the vertical laser lines - button (1d)
- (1d) 5. Mark the position of the visible laser line cross on the wall A (point 1).
- (1d) 6. Turn the complete unit 180° without altering the height of the laser.
- G3 7. Mark the position of the visible laser line cross on the wall B (point 2).
- G4 8. Now move the unit directly in front of wall B.
- G5 9. Set the unit's height so that the laser dot's height matches that of point 2.
10. Without changing the height of the laser, rotate it 180° to place the beam near the mark on the first wall (step 3 / point 1).

Measure the vertical distance between point 1 and point 3. The difference must not be greater than:

S		Maximum permissible difference	
5 m	16'5"	1,0 mm	5/128"
10 m	32'10"	2,0 mm	5/64"
15 m	49'3"	3,0 mm	1/8"
20 m	65'8"	4,0 mm	5/32"

1 2. Horizontal checking - inclination of the laser line

Check the laser line for inclination and perfectly straight projection

1. Mark three points (1, 2 and 3) on the floor at a distance of 5 m / 16'5" from each other; the points must be in a perfectly straight line.
- 12 2. Position the laser at distance S = 5 m / 16'5" from the line and exactly in front of the middle point you marked = position X
3. Switch the unit on - button (1a)
4. Switch on the horizontal laser line - button (1c)
5. Measure the height of the laser line at the points. Measurements X1 - X3
- 13 6. Reposition the instrument.
7. Position the laser at distance S = 5 m / 16'5" from the line and exactly in front of the middle point you marked = position Y
8. Measure the height of the laser line at the points. Measurements Y1-Y3

$$\Delta_1 = X_1 - Y_1 \quad \Delta_2 = X_2 - Y_2 \quad \Delta_3 = X_3 - Y_3$$

		L		Δ ges 1 or Δ ges 2	
Δ ges 1 = $\Delta_1 - \Delta_2 \leq \pm 2$ mm	$\pm 5/64$ "	5 m	16'5"	2,0 mm	5/64"
Δ ges 3 = $\Delta_3 - \Delta_2 \leq \pm 2$ mm	$\pm 5/64$ "	7,5 m	24'8"	3,0 mm	1/8"
		10 m	32'10"	4,0 mm	5/32"

When calculating, always take note of the preceding prefix !

LA-180L:

Registering the REC 410 Line RF receiver with the laser transmitter :

1. Switch off the laser transmitter (button 1a)
2. Press and hold down buttons (1c) and (1d).
3. Switch the unit on - button (1a)
4. The laser transmitter is in registration mode.
The LEDs (red and green) flash alternately.
5. Press the button "automatic precision alignment" (d) on the REC 410 Line RF receiver.
6. The red and green LEDs on the laser transmitter will flash 3 times for 3 seconds:
-> Registration was successfully completed.



(1a)



(1c)



(1d)



(d)

Replacing the batteries

Open the battery compartment (4) by moving it in the direction of the arrow.
Insert new batteries following the instructions in the battery compartment.



Tip:

Remove the batteries if the unit will not be used for a long period !

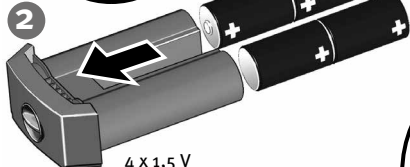
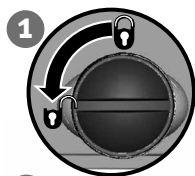

4 x 1,5 V
mono cells alkaline,
size D, LR 20

or STABILA battery unit

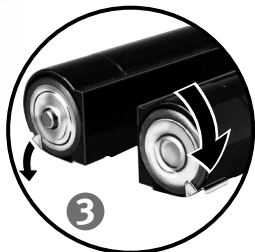
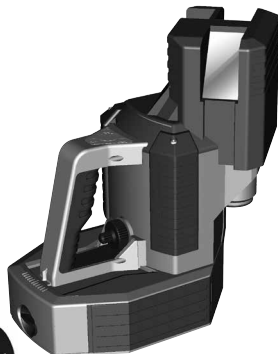

Operating status display and error messages via the LEDs

- Illuminated **green** LED → laser in operation
- Illuminated **green** LED + laser beam **flashing** → The laser levels itself automatically
- Flashing green** LED + laser beam **flashing** → The unit is inclined too much
+ is outside the self-levelling range
+ the laser cannot level itself automatically
- Illuminated **red** LED → laser in operation
→ battery voltage very low
→ battery replacement required imminently
- Illuminated **red** LED + laser beam **flashing** → The laser levels itself automatically
→ Battery voltage very low
→ Battery replacement required imminently
- Flashing red** LED + laser beam **flashing** → Battery voltage very low
→ The unit is inclined too much
+ is outside the self-levelling range
+ the laser cannot level itself automatically
- The LEDS flash red + green** + laser cannot be seen → The temperature in the unit is over 50°C / 122°F
→ The laser diodes have been switched off to protect against overheating
→ Place the unit in the shade to be able to continue working.
→ The laser is not working
- The LEDS flash red + green alternately** The appliance is in registration mode
- The LEDS flash 3 x during a period of 3 seconds** The registration was successful



Do not store the laser when wet. Dry the laser and case before putting the laser away.



IP 54

Do not submerge the laser.



Do not unscrew !

Care and maintenance

- Dirty lens glass on the beam emitter detracts from the quality of the beam. It should be cleaned with a soft cloth.
- Clean the laser unit with a damp cloth. Do not spray or immerse the unit! Do not use solvents or thinners!

The LA180L multi-line laser must be handled carefully, in the same way as any precision optical instrument.

Technical data

Laser type: line: Red diode laser, pulsed line-laser
wavelength 630- 660 nm

Laser type plumb-line point: wavelength 650- 660 nm

Output: < 1 mW, Laser Class 2

This product complies with 21CFR parts 1040.10 and 1040.11.

Self-levelling range: $\pm 5^\circ$

Levelling accuracy*

Middle of the laser line:	$\pm 0,07$ mm/m	$\pm 3/32$ " over 100 ft
Laser line inclination horizontal:	$\pm 0,10$ mm/m	$\pm 1/8$ " over 100 ft
Laser line inclination vertical :	$\pm 0,10$ mm/m	$\pm 1/8$ " over 100 ft

90° accuracy*

vertical laser lines:	$\pm 0,20$ mm/m	$\pm 1/4$ " over 100 ft
vertical and horizontal laser line:	$\pm 0,20$ mm/m	$\pm 1/4$ " over 100 ft
Plumb-line beam:	$\pm 0,20$ mm/m	$\pm 1/4$ " over 100 ft

Batteries: 4 x 1,5 V Monocells alkaline, size D, LR20

Operating life: approx. 20 hours (alkaline) 4 x 1,5 V

Operating temperature range: -10°C to $+50^\circ\text{C}$ / 14°F to $+122^\circ\text{F}$

Storage temperature range: -25°C to $+70^\circ\text{C}$ / -13°F to $+158^\circ\text{F}$

* When operated within specified temperature range.

Subject to technical modifications.



835034a

09 2022

STABILA Messgeräte

Gustav Ullrich GmbH

Landauer Str. 45

76855 Annweiler

Germany



www.stabila.com